

## High Productivity Cooking thermaline 80 - Freestanding Electric Multi Braiser, 1/1GN, 1 Side, H=800

ITEM # \_\_\_\_\_

MODEL # \_\_\_\_\_

NAME # \_\_\_\_\_

SIS # \_\_\_\_\_

AIA # \_\_\_\_\_



**588277 (MAAAFADDAO)** Electric Multi Braiser, one-side operated, 1/1 GN

### Short Form Specification

#### Item No.

Unit constructed according to DIN 18860\_2 with 20 mm drop nose top and 70 mm recessed plinth. Internal frame for heavy duty sturdiness in stainless steel. 2 mm top in 1.4301 (AISI 304). Flat surface construction, easily cleanable. THERMODUL connection system enables seamless worktop when units are connected and avoids soil penetrating. Multi-purpose cooking appliance which can be used to shallow fry, cook liquids or as a bain marie. 18 mm-thick stainless steel plated bottom, seamlessly welded to the chrome nickel steel well. Powerblock heating system for optimal temperature distribution, which can be set up to 280°C. Interior pan dimensions allows the use of GN containers. Large drain hole to drain the cooking juices into a large collector. All-round basin raised edges to protect against soil infiltration. Overheat protection switches off the supply in case of overheating. Standby function saves energy and quickly recovers maximum power. Metal knobs with embedded hygienic silicon "soft" grip enable easier handling and cleaning. IPX5 water resistant certification. Configuration: Freestanding, one-side operated.

### Main Features

- Large drain hole on cooking surface permits the draining of residual cooking juices into a large collector placed under the cooking surface.
- Multi purpose cooking appliance that can be used to shallow fry, cook liquids or even as a bain marie. Unit can be used for sautéing, poaching, steaming, simmering, stewing, braising, boiling and preparing white sauces.
- Overheat protection: the temperature sensor switches off the supply in case of overheating.
- All major components may be easily accessed from the front.
- THERMODUL connection system creates a seamless work top when units are connected to each other thus avoiding soil penetrating vital components and facilitating the removal of units in case of replacement or service.
- Metal knobs with embedded hygienic "soft-touch" grip for easier handling and cleaning. The special design of the controls prevents infiltration of liquids or soil into vital components.
- Powerblock heating system for optimal temperature distribution.
- Raised edge all around the well to protect from infiltration of dirt from worktop.
- Temperature can be set up to a maximum of 280 °C.
- Interior dimensions of the well enables the use of GN containers.
- Large visible digital display manufactured in tempered glass to resist heat and chemicals, showing temperatures or power settings. The display also shows on/off status of the appliance and on/off status of the heating elements.
- Handles are ergonomically designed with silicon "soft" grip for easy handling and cleaning.

### Construction

- An 18 mm thick stainless steel plated bottom is seamlessly welded into the chrome nickel steel well.
- Rounded corners and edges aid cleaning.
- Storage space in the base of the appliance that can accept GN1/1 containers.
- IPX5 water resistance certification.
- 2 mm top in 1.4301 (AISI 304).
- Flat surface construction with minimal hidden areas to easily clean all surfaces
- Unit constructed according to DIN 18860\_2 with 20 mm drop nose top and 70 mm recessed plinth.

APPROVAL: \_\_\_\_\_

- Internal frame for heavy duty sturdiness in stainless steel.

### Sustainability



- Standby function for energy saving and fast recovery of maximum power.

### Optional Accessories

- Lid for multi braisers, 1/1 GN PNC 910625
- Connecting rail kit, 800mm PNC 912500
- Stainless steel side panel, 800x800mm, freestanding PNC 912508
- Stainless steel front kicking strip, 400mm width PNC 912594
- Stainless steel side kicking strips left and right, freestanding, 800mm width PNC 912619
- Stainless steel side kicking strips left and right, back-to-back, 1610mm width PNC 912625
- Stainless steel plinth, freestanding, 400mm width PNC 912821
- Connecting rail kit: modular 80 (on the left) to ProThermetic tilting (on the right), ProThermetic stationary (on the left) to ProThermetic (on the right) PNC 912971
- Connecting rail kit: modular 80 (on the right) to ProThermetic tilting (on the left), ProThermetic stationary (on the right) to ProThermetic (on the left) PNC 912972
- Endrail kit, flush-fitting, left PNC 913109
- Endrail kit, flush-fitting, right PNC 913110
- Scraper for smooth plates PNC 913119
- Blades with rounded sides for scraper PNC 913123
- Endrail kit (12.5mm) for thermaline 80 units, left PNC 913200
- Endrail kit (12.5mm) for thermaline 80 units, right PNC 913201
- Stainless steel side panel, left, h=800 PNC 913216
- Stainless steel side panel, right, h=800 PNC 913217
- Bottom plate for multibraiser 1/1 GN PNC 913228
- Insert profile D=800mm PNC 913230
- Perforated shelf for warming cabinets and cupboard bases (one-side operated TL80-85-90 and two-side operated for TL80) PNC 913233
- Energy optimizer kit 14A - factory fitted PNC 913244
- Endrail kit, (12.5mm), for back-to-back installation, left PNC 913249
- Endrail kit, (12.5mm), for back-to-back installation, right PNC 913250
- Endrail kit, flush-fitting, for back-to-back installation, left PNC 913253
- Endrail kit, flush-fitting, for back-to-back installation, right PNC 913254
- Side reinforced panel only in combination with side shelf, for freestanding units PNC 913257

- Side reinforced panel only in combination with side shelf, for back-to-back installations, left PNC 913273
- Side reinforced panel only in combination with side shelf, for back-to-back installation, right PNC 913274
- Shelf fixation for TL80-85-90 one-side operated, TL80 two-side operated PNC 913279
- Filter W=400mm PNC 913663
- Stainless steel dividing panel, 800x800mm, (it should only be used between Electrolux Professional thermaline Modular 80 and thermaline C80) PNC 913669
- Electric mainswitch 25A 4mm<sup>2</sup> NM for modular H800 electric units (factory fitted) PNC 913676
- Stainless steel side panel, 800x800mm, flush-fitting (it should only be used against the wall, against a niche and in between Electrolux Professional thermaline and ProThermetic appliances and external appliances - provided that these have at least the same dimensions) PNC 913685

### Recommended Detergents

- C41 HI-TEMP RAPID DEGREASER, 1 pack of six 1 lt. bottles (trigger incl.) PNC 0S2292

Front

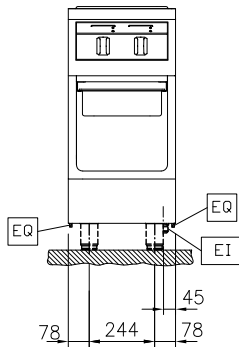

Side

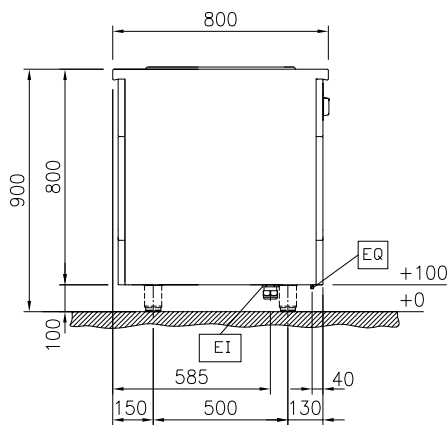

EI = Electrical inlet (power)

Top

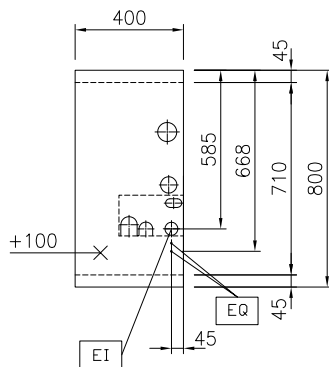

### Electric

Supply voltage:	400 V/3N ph/50/60 Hz
Total Watts:	5 kW

### Key Information:

Usable well dimensions (width):	306 mm
Usable well dimensions (height):	110 mm
Usable well dimensions (depth):	510 mm
Cooking Well Height:	110 mm
Well Capacity, Max:	ISO 9001; ISO 14001 lt
Working Temperature MIN:	120 °C
Working Temperature MAX:	280 °C
External dimensions, Width:	400 mm
External dimensions, Depth:	800 mm
External dimensions, Height:	800 mm
Storage Cavity Dimensions (width):	340 mm
Storage Cavity Dimensions (height):	330 mm
Storage Cavity Dimensions (depth):	740 mm
Net weight:	70 kg
Configuration:	Rectangular;Fixed

### Sustainability

Current consumption:	7.22 Amps
----------------------	-----------